

BRAILLO ● 300

Compact interpoint Braille printer for large volume production



- Rugged construction for large volume production of Braille.
- Low noise.
- Prints both 6 and 8 dot Braille.
- Modular design, easy to service.
- Uses standard fanfolded paper in a variety of formats.
- Prints simultaneously on both sides of paper.
- 2 years warranty on parts.
- Adjustable speed between 600 and 900 pages per hour continuous printing.
- High Braille quality. Each document is an original.
- The printing system is based on Braillo 200 with more than 15 years of experience.

Technical Specifications Braillo 300

Format:

Char. per line:	10 - 42 characters
Sheet length:	4 - 14 inches
Sheet width:	140 - 330 mm
Page layout:	Normal / Z-fold
Page 1:	Up / Down
Printing Mode:	Single / Interpoint
Page Length:	No form feed / Normal / Normal -1 to -9 lines
Braille cell:	Standard medium 6 or 8 dot
Line spacing:	From 0.3175 to 10.16 mm. Standard is 5.08 mm
Paper Weight:	120 - 180 g/m ² , Recommended 150 g/m ²

Adjustable

Printing Speed: 200 to 300 characters per second, approx. 600 - 900 printed pages per hour

Electrical:

Voltage:	Single phase 230V (+/- 10 %), 50/60Hz
Current:	Approx. 4 A max
Fuse Printer:	10 A
Power:	Approx. 1000 W max

Communication with the computer:

USB
Ethernet
Serial on RS 232 C (9 pin D-sub male).

Environment:

Temperatures:	15 - 30°C (60 - 86°F)
Rel. Humidity:	40 - 60%

Measurements:

Height:	650 mm
Width:	700 mm
Length:	920 mm
Weight:	145 kilos



Adjustable speed



Touch panel

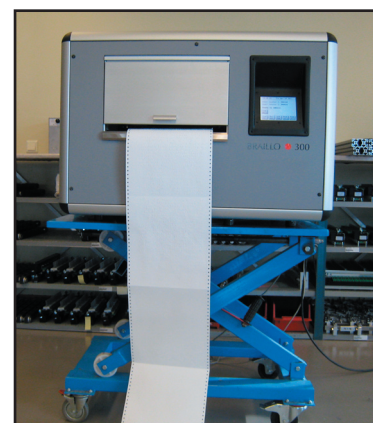

Easy to place on a table

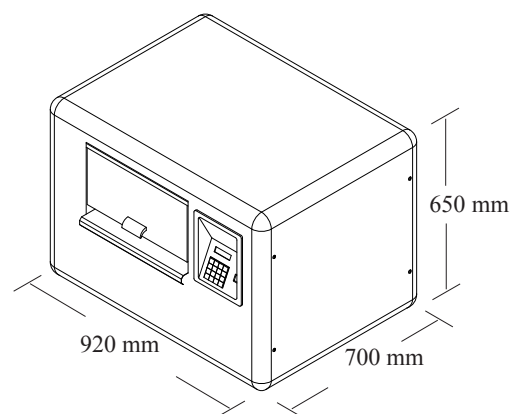

The manufacturer reserves the right to change the specifications without further notice.

Produced and marketed by:

Distributed by:

BRAILLO NORWAY AS

P. O. Box 447

3101 Tønsberg, Norway

Phone: +47 33 00 28 70

Fax: +47 33 00 28 71

E-mail: braillo@braillo.no

Internet: www.braillo.com