

BRAILLO ● 650 SF

Advanced interpoint Braille printer for large volume production



- Rugged construction for large volume production of Braille.
- Built-in Paper Cutter.
- Uses standard paper rolls up to 1 meter in diameter.
- Modular design, easy to service.
- Stack sheets, adds a cover, then staples and folds to make a finished book.
- 2 years warranty on parts.
- Prints simultaneously on both sides of paper.
- Adjustable speed between 400 and 650 characters per sec. continuous printing.
- High Braille quality. Each document is an original.
- The printing system is based on Braillo 400 S with more than 15 years of experience.

Technical Specifications Braillo 650 SF

Format:

Line length:	31 - 44 characters
Sheet length:	Max 330 mm (13 inches)
Sheet width:	4 page, min 417 mm, max 585 mm (16,4 to 23 inch)
Page 1:	Up / Down
Printing Mode:	Single / Interpoint
Margins:	Inner/Outer 12,7 - 50,8 mm (0,5 - 2 inches)
Page Length:	Max 30 lines per page
Braille cell:	Standard medium 6 dot
Line spacing:	Fixed 5 mm (0,2 inches)
Paper Weight:	120 - 180 g/m ² , Recommended 150 g/m ²



Touch panel

Adjustable

Printing Speed:	400 to 650 characters per second, no of pages per hour is dependent on page format.
------------------------	---

Electrical:

Voltage:	Single phase 230V (+/- 10 %), 50/60Hz
Current:	Approx. 8.5 A max
Fuse Printer:	10 A
Power:	Approx. 2000 W max

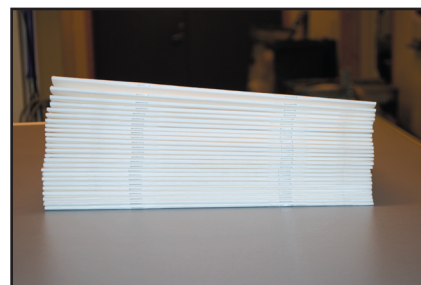

Finished books from B 650 SF

Communication with the computer:

USB
Ethernet
Serial on RS 232 C (9 pin D-sub male)

Environment:

Temperatures:	15 - 30°C (60 - 86°F)
Rel. Humidity:	40 - 60%

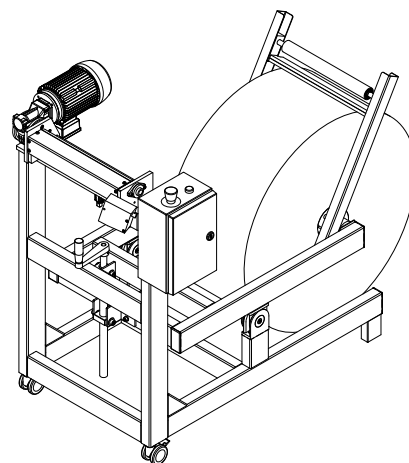

Paper Roll Feeder

Measurements:

Height:	1500 mm
Width:	1027 mm
Length:	4060 mm (+ approx. 2000 mm for paper roll loading and book collecting)
Weight:	570 kilos

The manufacturer reserves the right to change the specifications without further notice.

Produced and marketed by:

Distributed by:

BRAILLO NORWAY AS

P. O. Box 447

3101 Tønsberg, Norway

Phone: +47 33 00 28 70

Fax: +47 33 00 28 71

E-mail: braillo@braillo.no

Internet: www.braillo.com
